

IPPC-9171G

17" SXGA TFT LCD Pentium® 4 Industrial Panel PC with 2 x PCI Slots



Introduction

The IPPC-9171G is an Industrial Panel PC with support for Pentium 4 processors to meet the demands of today's applications. The IPPC-9171G is a rugged unit with an aluminum panel, tempered glass, 17" TFT LCD, a stainless steel structure and two expansion slots. The IPPC-9171G is rugged enough to handle the toughest industrial operating environments.

With optional mounting accessories from panels to racks, it can be mounted almost anywhere.

Specifications

General

- **BIOS** Award® 256KB Flash BIOS
- **Certifications** CCC, CE, FCC, UL, BSMI
- **Cooling System** 2 x 10.1 CFM fans w/50,000 hrs MTBF
- **Dimensions (W x H x D)** 482 x 354.8 x 162 mm (18.97" x 13.96" x 6.37")
- **Disk Drive Bay** Supports one 3.5" HDD and build-in slim type CD-ROM & FDD
- **Enclosure** Stainless steel back housing
10 mm thick aluminum front panel
- **Mounting** Panel, rack
- **Power Input** 100 ~ 240 V_{AC} @ 50 ~ 60 Hz, 4-2 A
- **Power Output** + 5 V @ 15 A, +12 V @ 5 A, -12 V @ 0.5 A
- **Power Supply** 180 W, MTBF: 100,000 hrs
- **Weight (Gross)** 15 kg (33.07lb)

System Hardware

- **Audio Ports** Mic-in, Line-in, Line-out, and game port
- **Chipset** Intel 845GV
- **CPU** Socket 478, Intel Pentium 4 up to 2.8 GHz
Intel Celeron® up to 2.5 GHz (400/533 MHz)
- **Expansion Slots** 2 x low-profile PCI
- **IEEE-1394 Ports** 2 x IEEE 1394 ports (Firewire)
- **Keyboard/Mouse** 1 x PS/2 mouse and keyboard interface
- **LAN** 1 x 10/100Base-T
- **Memory** Two 184 pin DDR DIMM sockets supports up to 2 GB (Clock 266)
- **Parallel Port** 1 x standard parallel port
1 x enhanced parallel port, supports SPP/EPP/ECP parallel mode. BIOS configurable to LPT1, LPT2, LPT3 or disabled
- **PCMCIA Slots** 2 x Type II

Features

- Intel® Pentium® 4 processor up to 2.8 GHz
- 17" SXGA TFT LCD provides vivid, sharp and large images
- Offers two expansion slots for PCI add-on cards
- Heavy-duty stainless steel chassis with aluminum front panel
- Strengthened glass protects the front panel from shock damage and is NEMA4/IP65 compliant
- Front access USB connector
- Supports industrial mounting rack and panel mounting
- Supports resistive touchscreen (Optional)

- **Serial Ports** 1 x RS-232, 1 x RS-232/422/485
- **USB Ports** 5 x USB 2.0 (One at front)
- **Video Port** S-Video

LCD Display

- **Backlight Life** 50,000 hrs
- **Contrast Ratio** 800 : 1
- **Display Size** 17"
- **Display Type** SXGA TFT LCD
- **Luminance** 300 cd/m²
- **Max. Colors** 16.2 M (RGB 6-bit + FRC data)
- **Max. Resolution** 1280 x 1024
- **OSD Control** LCD ON/OFF, Brightness down, up
- **Viewing Angle (H/V°)** 160/160

Touchscreen (Optional)

- **Interface** USB
- **Lifespan** 10 million touch lifetime at the single point
- **Light Transmission** 80%
- **OS Support** Windows 95/98/2000/XP, Linux
- **Type** Analog resistive (8-wire)

Environment

- **Humidity** 5 ~ 85% RH @ 40° C (non-condensing)
- **Ingress Protection** Front panel: NEMA4/IP65
- **Operating Temperature** 0 ~ 50° C (32 ~ 122° F)
- **Storage Temperature** -20 ~ 60° C (-4 ~ 140° F)
- **Vibration Protection** 5 ~ 500 Hz, 1 G_{RMS} random vibration (operating)

Dimensions

Unit: mm

IPPC-9171GA

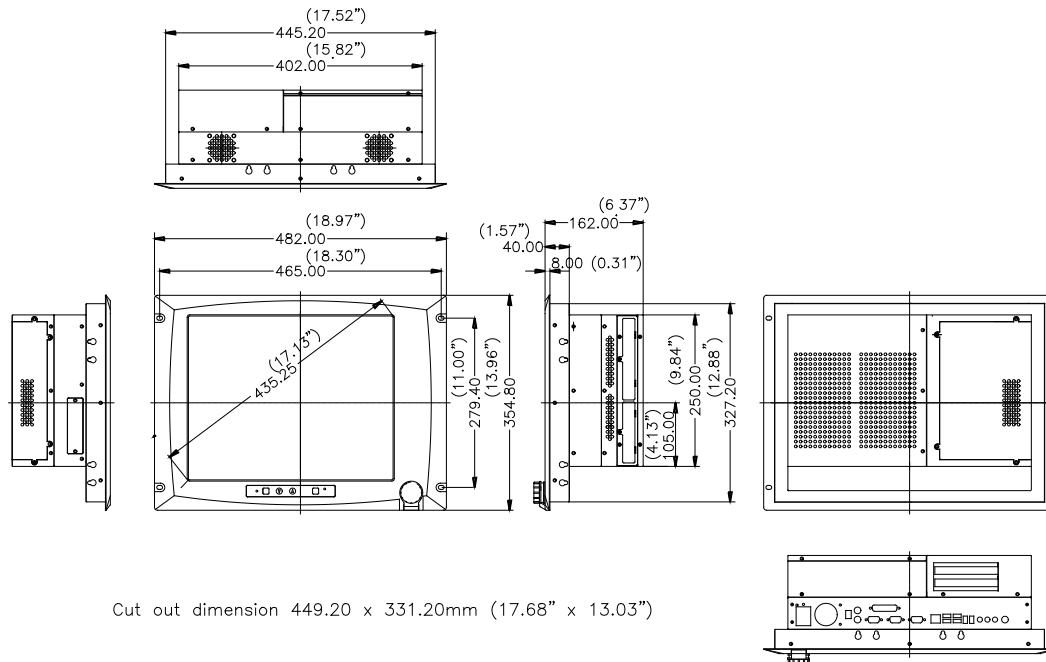

Ordering Information

- **IPPC-9171G-XAE** 17" SXGA TFT LCD Pentium 4 Industrial Panel PC with 2 x PCI Slots
- **IPPC-9171G-RAE** IPPC-9171G-XAE with resistive touchscreen

Notes:

1. When panel mounting, the panel's thickness can not be over 10 mm
2. 4 mm stainless front panel supported by request

Accessories

- **1702002600** Power Cable US Plug 1.8 M
- **1702002605** Power Cable EU Plug 1.8 M
- **1702031801** Power Cable UK Plug 1.8 M
- **1702031836** Power Cable China/Australia Plug 1.8 M

Back View



Bottom View

